

# ENERGY CHARACTERISTICS OF SOLAR PHOTOELECTRIC INSTALLATIONS UNDER THE COMBINED PRODUCTION OF HEAT AND ELECTRIC ENERGY IN THE CONDITIONS OF UZBEKISTAN

D.R. Otamirzaev<sup>1</sup>

***Abstract**---The possibility of increasing the total conversion coefficient of solar installations by generating heat and electricity from one receiving surface is being considered. To achieve this goal, a thermophotovoltaic installation is proposed that combines a photovoltaic module and a thermal collector. For experiments, the installation was used: combined thermophotovoltaic conversion of solar energy. The results of comparative experimental studies of the proposed facilities are presented.*

***Keywords**---thermal collector; photovoltaic installation; thermophotovoltaic installation; silicon solar cells; combined conversion of solar energy; conversion factor.*

---

## I. Introduction

Currently, as traditional energy sources decrease, much attention is paid to the use of renewable energy sources and is growing all over the world, including in Uzbekistan great efforts are made to develop the use of renewable energy sources [1]. Solar photovoltaic converters are the most common type of renewable energy. When using photovoltaic installations, their main disadvantage is the low efficiency of converting the solar radiation flux into electrical energy (industrial photocell efficiency is 15–20%). At the same time, the solar collectors used to heat the coolant have a thermal efficiency several times higher. Therefore, to increase the efficiency of the system, it is advisable to use a combined solar installation that combines a thermal collector and a photovoltaic module.

With the development of science and technology, more and more solar installations are appearing, during the work of which thermal and electric energy can be generated simultaneously from the same working surface. With certainty, they can be attributed to a new class of solar technology - thermophotovoltaic solar installations, which simultaneously convert all the incident solar radiation into heat and electricity, i.e. at the same time they heat the coolant and are an electric DC generator [2].

The use of combined thermo-photovoltaic installations provides a significant saving of materials for their manufacture per unit of power, increases their total conversion coefficient and efficiency. This is because the absorbers of solar thermal

---

<sup>1</sup>"Namangan institute of engineering and technology" [otamirzaev.don93@mail.ru](mailto:otamirzaev.don93@mail.ru)

systems and photovoltaic converters of solar cells convert different wavelengths of the solar spectrum, so from the same work surface you can get both thermal and electrical energy without reducing the efficiency of the thermal and electrical parts. The production of thermophotovoltaic panels based on serial plants will reduce the cost of producing absorbers with expensive selective coatings and materials for the production of structures of photovoltaic modules by combining them into one unit [3].

There are combined solar phototherm converters. In which excess heat from the back surface serves as a source of energy for thermocouples located there [4].

## **II. Research problem statement**

Modern industrial solar cells made of monocrystalline and polycrystalline silicon have a flat design, their efficiency is 17 - 20%, with an absorption coefficient of up to 95%. When converting solar energy, 80% of the energy goes mainly to heat the elements, which only worsens their quality work. By positioning the solar cells on top of the solar absorber thermal absorber, with effective heat transfer creates the opportunity to increase the efficiency of the entire installation. The removal of heat by the heat carrier circulating along the solar system circuit prevents the overheating of the photoconverters and, accordingly, increases the total generation of electric energy. The high absorption coefficient of solar cells allows up to 80% of the solar energy absorbed by them to go on heating the receiving surface of the thermal absorber. A conversion factor of up to 80% is a high indicator for many absorbers of industrial thermal solar installations.

## **III. The purpose and objectives of the study**

The purpose of the study is to conduct an experiment to confirm theoretical data on an increase in the total conversion coefficient of incident solar radiation flux by a photovoltaic installation and an increase in power characteristics per unit area of its receiving surface when using combined generation of heat and electric energy.

The experiments on measuring the energy characteristics of the solar installation were carried out in full-scale conditions on the territory of the open laboratory site of the Faculty of Automation and Energy of the Namangan Engineering and Technology Institute of the Republic of Uzbekistan from May to July 2019.

In this work, we used the method of direct measurements of the short circuit current and the open circuit voltage of the photoconverter with a no-load mode and methods of temperature measurements of the coolant. The studies were carried out in natural conditions on an open area on clear days, with natural sunlight and maximum illumination (about 1000 W/m<sup>2</sup>). The condition for the experiment was the constancy of the intensity of solar radiation.

During the work, a solar installation was used (Fig. 1), 1 m long and 0.6 m wide, intended directly for installation of roofing of residential buildings. The combined installation itself consists of separate photovoltaic cells (cells) installed between the polypropylene plane and the protective glass, there are technological ribs on the sides, the back part is connected to the heat exchanger, the heat exchanger is a metal sheet attached to the ribs of the solar installation and two fittings for circulating the working fluid which attached to the tank. Inside the combined installation is a liquid coolant.



Fig. 1. Thermophotovoltaic solar installation

On the receiving surface of the installation are solar cells capable of generating electrical energy. Elements cover from 8/10 to 9/10 parts of the installation. Due to the lower temperature at the bottom of the heat exchanger during the circulation of the coolant, the elements are cooled, which improves the quality of their work. Since silicon solar cells transform the non-thermal part of the spectrum, there is a general increase in energy production. Factory efficiency of the used solar installation (with illumination  $E_0 = 1000 \text{ Wt/m}^2$ ) is 16%, the thermal efficiency of the proposed combined installation in stationary mode is 58%. Accordingly, the specific power of the solar battery can be up to  $160 \text{ Wt/m}^2$ , a heat collector –  $583 \text{ Wt/m}^2$ .

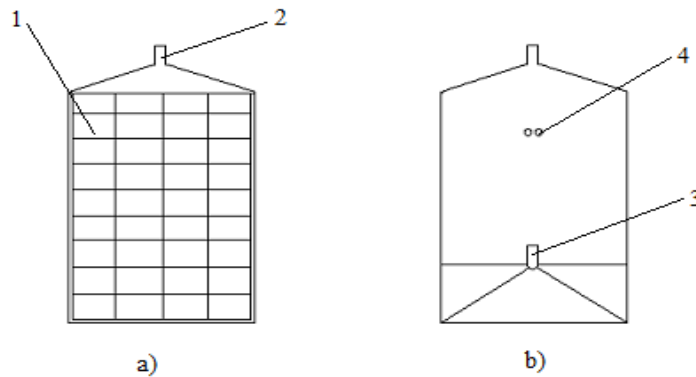

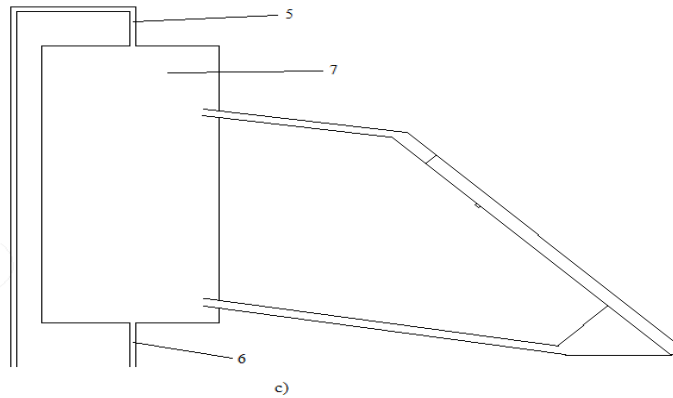

Fig. 2. Combined thermophotovoltaic installation:

1 - photovoltaic cells (cells), 2–3 - fittings for the inlet and outlet of the working fluid, connector for electrical wires, 5–6 - reservoir tubes, 7 - thermal energy reservoir.

The operation of the thermovoltaic installation is described by the method [5].

Maximum power  $P_{max}$ , produced by the solar battery:

$$P_{max} = F_{ff} I_{кз} U_{xx} = I_{max} U_{max} \quad (1)$$

where  $F_{ff}$  – current-voltage characteristic fill factor;  $I_{кз}$  – short circuit current;  $U_{xx}$  – open circuit voltage;  $I_{max}$  – current at operating point;  $U_{max}$  – operating voltage.

The efficiency of the photovoltaic solar battery is calculated according to the well-known formula:

$$\eta_{сб} = \frac{I_{max} U_{max}}{S_{\text{эл}} E_0} = \frac{P_{max}}{S_{\text{эл}} E_0} \quad (2)$$

where  $S_{\text{эл}}$  – usable area of solar cells,  $\text{m}^2$ ;  $E_0$  – work surface illumination,  $\text{Wt/m}^2$ .

Accordingly, the calculation of the thermal absorber is also performed by the known method [5]. Useful energy  $Q_u$ , allocated from the collector per unit time, W, is equal to:

$$Q_u = F_R A [I_T (\tau \alpha) - U_L (T_i - T_a)], \quad (3)$$

where  $A$  – collector area,  $\text{m}^2$ ;  $F$  – coefficient of heat removal from the collector;  $I_T$  – flux density of total solar radiation in the plane of the collector (taking into account the angular coefficient  $R$ ),  $\text{Вт/м}^2$ ;  $\tau$  – transmittance of transparent coatings in relation to solar radiation;  $\alpha$  – solar collector absorptivity;  $U_L$  – total collector heat loss coefficient,  $\text{Вт/м}^2 \text{ grad}$ ;  $T_i$  – fluid temperature at the inlet to the collector (in nominal mode),  $^{\circ}\text{C}$ ;  $T_a$  – ambient temperature  $^{\circ}\text{C}$ .

For practical calculations, a simplified version of formula (3) is more applicable:

$$Q_u = S_{\text{ТК}} G C_p (T_{\text{ВЫХ}} - T_i), \quad (4)$$

where  $Q_u$  – solar collector thermal power  $P_{\text{ТК}}$ ;  $S_{\text{ТК}}$  – collector area,  $\text{m}^2$ ;  $T_{\text{ВЫХ}}$  – fluid temperature at the outlet of the collector.

Accordingly, the efficiency of the thermal collector is determined by the formula:

$$\eta_{ск} = \frac{P_{\text{ТК}}}{S_{\text{ТК}} E_0} \quad (5)$$

For combined installation of illumination  $E_0$  the same for the thermal and electrical parts, and the size of the areas  $S_{\text{ск}}$  and  $S_{\text{эл}}$  are equivalent, i.e. can be written:

$$\eta_{\text{ТК}} = \frac{P_{\text{ТК}}}{S_{\text{ТФУ}} E_0}; \quad \eta_{сб} = \frac{P_{сб}}{S_{\text{ТФУ}} E_0}, \quad (6)$$

where  $\eta_{\text{ck}}$ ,  $\eta_{\text{c6}}$  – thermal and electrical efficiency of the combined installation, respectively;  $P_{\text{TK}}$ ,  $P_{\text{c6}}$  – thermal and electrical efficiency of the combined installation, respectively;  $S_{\text{TPy}}$  – usable area of thermophotovoltaic installation, filled with solar cells.

The total power of the thermovoltaic installation is equal to the sum of the capacities of the thermal and photoelectric parts:

$$P_{\text{TPy}} = P_{\text{TK}} + P_{\text{c6}} = S_{\text{TPy}} E_0 (\eta_{\text{TK}} + \eta_{\text{c6}}) = S_{\text{TPy}} E_0 \eta_{\text{TPy}}, \quad (7)$$

where  $\eta_{\text{TPy}}$  – the total total efficiency of the thermophotoelectric installation (combined installation).

From this it can be seen that with an increase in the power taken from the solar installation due to the photoelectric component, its total efficiency increases, since the area and illumination of the working surface remain constant.

With incomplete coverage of the receiving surface of the combined installation with solar cells, formula (7) must be replaced:

$$P_{\text{TPy}} = S_{\text{TPy}} E_0 (\eta_{\text{TK}} + f_{\text{TPy}} \eta_{\text{c6}}) \quad (8)$$

where  $f_{\text{TPy}}$  – fill factor with solar elements of the receiving surface of the combined installation. In our case, it varies from 8/10 to 9/10.

The efficiency of solar cells decreases when heated:

$$\eta_{\text{c6}} = f_{\text{TPy}} \eta_0 (1 - k(T_i - T_0)) \quad (9)$$

where  $\eta_0$  – Photocell efficiency at  $T_0 = 25^\circ\text{C}$ ;  $T_i$  – temperature of the heated photocell (we consider it equal to the temperature of the liquid at the inlet to the collector); the drop in the efficiency of the solar cell depends on the temperature gradient  $k$  and ranges from 0.3 to 0.5% /  $^\circ\text{C}$  [6].

Given the above formula takes the form: 
$$P_{\text{TPy}} = S_{\text{TPy}} E_0 \frac{G C_p (T_{\text{Bыx}} - T_i)}{E_0} + S_{\text{TPy}} E_0 f_{\text{TPy}} \eta_0 (1 - k(T_i - T_0)), \quad (10)$$

By formulas (1) - (10), it is possible to determine all the parameters of a solar installation, taking into account the thermal and electrical parts.

#### IV. Research results

For the experiments, summer clear days with a high intensity of solar radiation were chosen. Illumination during measurements ranged from 980 to 1000  $\text{Wt}/\text{m}^2$ .

Passport data of the used solar battery:

Mark: AS- 100P,  $P_{\text{max}} = 100 \text{ Вт}$ ,  $U_{\text{xx}} = 21.8 \text{ V}$ ,  $I_{\text{кз}} = 6.1 \text{ A}$

The above values apply to:  $\text{AM}=1.5$   $E_0=1000 \text{ Вт}/\text{m}^2$   $T_c=25^\circ\text{C}$

Given the hot climate of Uzbekistan, the surface temperature of the solar photovoltaic converter can reach up to  $70^\circ\text{C}$  and higher, therefore, it is not possible to achieve the nominal values of energy characteristics in real conditions. In this regard, it is advisable to use combined installations.

In table 1. shows the measurement results of the proposed combined installation. Table 1.

№	Measurement time	SB surface temperature ( $^\circ\text{C}$ )	Short circuit current	Open circuit voltage
1	9.06.2019	30	5.65	21.7

2	25.06.2019	31	5.65	21.7
3	10.07.2019	30	5.64	21.7
4	21.07.2019	29	5.64	21.75

Graph- 1.

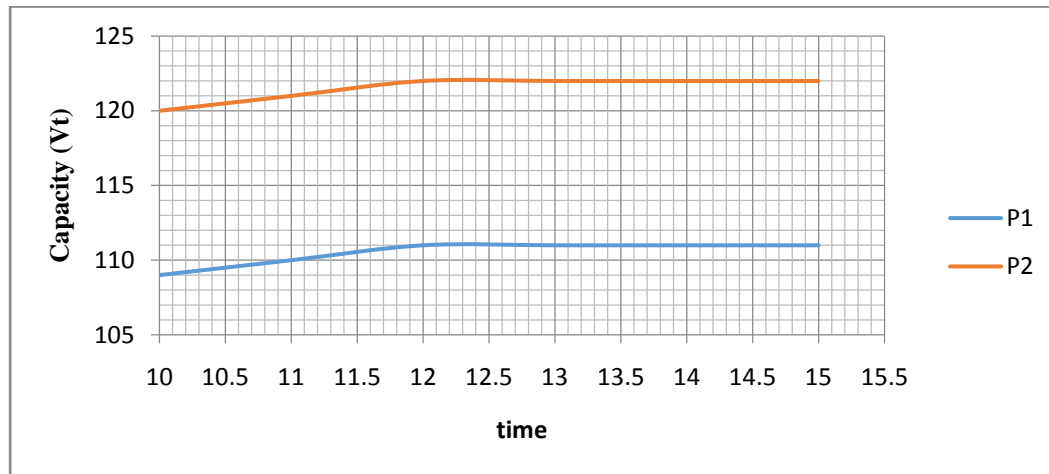

P1 - power of the photovoltaic battery, P2 - Electric power of the combined installation

The temperature gradient of the dependence of the efficiency of the solar cell  $k = 0.42 \frac{\%}{^{\circ}\text{C}}$  [6]. Using a combined installation, you can prevent a 3% reduction in the efficiency of the electrical part of the installation in real conditions. The thermal power of the combined installation according to formulas (4) is 583 watts.

## V. Conclusions

Studies show that the use of a thermal collector with solar photovoltaic converters significantly increases the efficiency of solar cells by 3% [6]. This is due to the fact that when the solar panels work without heat removal, the infrared thermal component of solar radiation is used to heat the solar cells, which can often lead to overheating and a decrease in the efficiency of solar cells [7, 8].

As a result of the research, the following results were obtained:

We can conclude that the efficiency of solar installations with combined generation of electric and thermal energy [3, 4].

It is shown that from 1 m<sup>2</sup> of the surface of the developed combined installation it is possible to obtain up to 160 W of electric and about 583 W of thermal power.

The total solar energy conversion coefficient of the combined installation is increased to 75%. Despite the fact that the electrical efficiency of solar cells used in research is about 17%, and the thermal efficiency of the installation can be up to 58%.

Using the developed installation in residential buildings with a continuous source of water is effective.

## REFERENCES

- [1] Law of the Republic of Uzbekistan ON THE USE OF RENEWABLE ENERGY SOURCES Tashkent, May 21, 2019, No. 3PY-539
- [2] Kuznetsov K.V., Tyukhov I.I., Sergievsky E.D. The study of the characteristics of the solar air hybrid collector // Energy supply and energy saving in agriculture: 6th Intern. scientific and technical conf., May 13-14, 2008 Moscow, GNU VIESH, 2008. Part 4. P. 227 - 231.
- [3] Pat. 150121 RF, IPC H 01 L 31/00. Phototherm transducer of solar energy / V.V. Kuvshinov, A.I. Bashta, V.A. Safonov; patent holder V.V. Kuvshinov. Application No. 2014149414/93; declared 10/17/2014; publ. 01/27/2015, Bull. No. 3.
- [4] Patent FAP 00793 Phototherm Converter / Lutullaev S.L., Tursunov M.N., Dadamuhamedov S., Yuldoshev I.A. Uz
- [5] Kuvshinov V.V. Methods for calculating and improving the efficiency of using photovoltaic installations // Sat. scientific tr SNUYE and P. 2013. Issue. 3 (47). S.166 -172.
- [6] Arbuzov Yu.D., Evdokimov V.M. Fundamentals of Photoelectricity. M.: GNU VIESH, 2007.292 s.
- [7] Rauschenbach G. Handbook for the design of solar panels. M.: Energoatomizdat, 1983.397 s
- [8] Shidhaye SS, Lotlikar VM, Ghule AM, Phutane PK, Kadam VJ. "Pulsatile Delivery Systems: An Approach for Chronotherapeutic Diseases." Systematic Reviews in Pharmacy 1.1 (2010), 55-61. Print. doi:10.4103/0975-8453.59513
- [9] Kuvshinov V.V. The use of solar concentrators to increase the power characteristics of network photovoltaic stations // Sat. scientific works SNUYaEiP. Sevastopol: SNUYaEiP, 2014. Issue. 1 (49). S. 144 - 149.
- [10] Jayasarathi,M.,Rajeshwari,S., Shiny Mercy,I., &Rathika,S.K.B. (2019). Enhanced on Data Encryption Standard for Secured Cloud Storage. Bonfring International Journal of Software Engineering and Soft Computing, 9(1), 7-10.
- [11] Kavya,M.S.,Dr.Geetha,B.G., &GokulRaaja,J.M. (2019). Android Application Development for Textile Industry. Bonfring International Journal of Software Engineering and Soft Computing, 9(1), 11-14.
- [12] Namiot, V., Shchurova, L. On quantum-mechanical measurements and processes of development of intelligence (2019) NeuroQuantology, 17 (9), pp. 1-8.
- [13] Obies, O.J., Mutar, M.A., Kadhim, R.G. Synthesis and characterizations of polyaniline/nylon(6) composites, electrical properties and thermal stability (2019) NeuroQuantology, 17 (11), pp. 26-33.