

# POWER FACTOR CONTROL IN LOW VOLTAGE ELECTRIC NETWORK IN OPTIMUM AND EFFICIENT POWER POSITION USING MICROCONTROLLER

<sup>1</sup>Sukenda, S.Kom., M.T, <sup>2</sup>Wawan Hermawan

**ABSTRACT**---Electrical energy is a very important requirement, interruption of electrical energy results in many activities that are interrupted and even stopped. Saving electricity is a necessity, because in the future the supply of electrical energy can be limited, the act of reducing the use of electrical energy is the right solution. Electricity energy savings can be done in several ways, saving energy by turning off some electricity loads, saving energy by installing energy-saving electrical loads, and saving energy that does not reduce or install energy-efficient electrical loads, but reduces or even eliminates all electric power. or increase the power factor of the inductive, energy-saving energy by installing capacitors in the circuit or electricity network, the installation of capacitors can also be useful to optimize the power installed on the electricity grid of PLN customers. The installation of capacitors on the electricity network must not be arbitrarily installed must pay attention to the nature of the electrical load, which means that not all electrical loads can be repaired and must be repaired by the power factor. From this description the authors build a power factor control prototype, this system is built to control the capacitors installed on the electricity network, so that the capacitors are not installed or installed in accordance with what is needed on the electricity network, in addition to this the capacitor size must also be in accordance with the requirements on the network, so the microcontroller will direct how many capacitors must be installed with the help of a relay module. In order for the microcontroller to be able to control the relay module there must be data coming in, namely by installing multiple PZEM-004t measuring devices, from the measurement data it can be known whether the network requires capacitors or not, and if capacitors require how much capacitors must be installed on electric network. With this system, consumers can optimize power in accordance with the amount of installed power that we buy from PLN, and besides that we can find out the amount of voltage, current and power used at that time.

**Keywords**---Power factor, PZEM-004t, Capacitors, Energy saving, Microcontroller

---

## I. Introduction

Electricity installed in a house is limited by Miniature Circuit Breaker (MCB), which functions as an electrical circuit breaker at overload, as well as safety when a short circuit occurs. The electrical power installed in a house, for

---

<sup>1</sup>Widyatama University, Bandung, 40125, Indonesia  
Email: kenda@widyatama.ac.id

<sup>2</sup>Widyatama University, Bandung, 40125, Indonesia  
Email: walwan@yahoo.com

example 450 VA is limited by MCB of 2 amperes with a voltage of 220 volts, the voltage can be up to 220 volts can also go down, depending on whether or not good supply from the PLN, assuming the voltage is stable, then the power obtained by consumers, 440 VA. while to calculate the amount of electricity used for equipment and lighting, the units use watts, so there is a real difference in power used by consumers is not the same as the active power installed, the difference is called the power factor. So the real power is used by PLN to calculate the installed capacity of the installation while to calculate the amount of use active power is used.

Electrical power factor is the ratio between active power and real power. The power factor explains the ratio between active power and real power and is a standard measure of the efficiency of the electrical system. The value of a good power factor is close to the value of one, the greater the difference between active power and real power, the greater the loss experienced.

Active power and real power have little difference, that is, the only factor that distinguishes the multiplier from active power is the power factor, when the power factor is one, there is no difference between active power and real power. If the power factor is below one, for example 0.5, then the difference between the real power is twice the active power, there is an increase in the electric current which is doubled, because the voltage value is the same. Therefore the power factor must be corrected, so that the active power with real power is not too far different, to improve the power factor by installing capacitors Figure 2.1 in parallel between voltage and zero.

Improvement of power factor in the electricity network using capacitors with the appropriate value, resulting in optimal use of electric power, so that it can cope with and increase the load increase without adding additional supplies from PLN.

## II. Literature Review

In the theory of electricity, there are 3 characteristics of electrical loads, namely resistive, inductive and capacitive, usually the burden that affects electricity usage is the inductive load, which is the load contained in a coil or coil so that it has a low power factor. The low power factor can be corrected by installing capacitors on the load itself or as a whole on the electricity grid in parallel, a refrigerator electrical equipment (see table 2.1), when the refrigerator is running it does not install capacitors, the current used by the refrigerator is 0.64 amperes, and when the refrigerator attaches the capacitor, the current drops to 0.39 amperes.

Table 2.1.: Fridge Trial

No	Volt	Current	Active power (watts)	Real power (VA)	Power Factor
<b>Kulkas Tanpa kapasitor</b>					
1	228.4	0.64	82	146.18	0.53
<b>Kulkas dengan kapasitor 2 x 3.5 mikrofarad</b>					

1	228.6	0.39	81	89.154	0.91
---	-------	------	----	--------	------

In the refrigerator equipment experiment where the improvement of the power factor from 0.53 to 0.91 is almost close to 1, which is depicted in the power triangle see figure 2.1 Refrigerator Power Triangle, where the power factor is improved from 0.53 to 0.91, so the value of active power and apparent power difference is not too far apart..

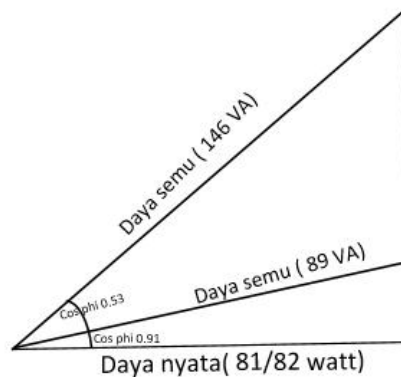

Figure 2.1: Power Refrigerator Triangle

So that the capacitor can be useful for the electricity network, the use of the capacitor must be controlled installation, i.e. when the capacitor is installed in the electrical installation, and what is the maximum value of the capacitor that must be installed, then it must be made a system so that the capacitor is installed in the electricity network as needed , following the calculation to find the value of the capacitor manually.

One refrigerator with power = 82 W, voltage = 220 V, power factor = 0.53 Then:

$$P = V.I.\text{Cos } \theta$$

$$I = P/V.\text{Cos } \theta = 80/220 * 0,53 = 82/116 = 0,7 \text{ A} \gg 700 \text{ mA}$$

Consumption needed in theory if the Cos  $\theta$ , is 0.95:

$$I = P/V.\text{Cos } \theta = 80/220 * 0,95 = 80/209 = 0,382 \text{ A} \gg 382 \text{ mA}$$

What is the percent savings:

$$700 - 382 = 318 \gg \pm 40\%$$

How to find the value of a capacitor:

$$\text{Cos } \theta_1 = 0,53 \gg \theta_1 = \text{Cos}^{-1} * 0,53 = 57,995$$

$$\text{Cos } \theta_2 = 0,95 \gg \theta_2 = \text{Cos}^{-1} * 0,95 = 18,1949$$

Active Power P1 = 82W

$$\text{Real Power } S1 = V.I = 154.71 \text{ VA}$$

Or

$$S1 = P / \cos \theta = 82 / 0.53 = 154.71 \text{ VA}$$

$$\text{Reactive Power } Q1 = S.\sin \theta$$

$$= 154.71 * \sin 57.995$$

$$= 131.19 \text{ VAR}$$

$$P2 = P1 = 82 \text{ W}$$

$$S2 = V.I = 220 * 392,3 \text{ mA} = 86.32 \text{ VA}$$

$$Q2 = S.\sin \theta$$

$$= 86.32.\sin 18,1949$$

$$= 26.95 \text{ VAR}$$

Reactive power that must be eliminated :

$$\Delta Q = Q2 - Q1$$

$$= 26.95 - 131.19 = - 104.24 \text{ VAR}$$

The reactive power must be removed. So the capacitor used to get the angle ( $\Phi$ ) = 0.95 is:

$$C = Qc / -V^2\omega = - 104.24 / (220^2) * 2 * 314 * 50 = 6.9 \mu\text{F}$$

### III. Result

#### a. System planning

Multi measuring instrument PZEM-004T see picture Figure 3.21PZEM-004T, has 4 pins to connect to the microcontroller, and 4 connections to CT and to the load from the PLN, the connection to the microcontroller is the first 4 pins for power namely 2 pins to VCC and ground and 2 more pins to pins 10 and 11, for 4 more pins to load to measure voltage and energy and 2 more pins connected to CT to measure electric current.



Figure 3.1: PZEM-004t

Current, voltage, and power data from the measuring device are processed by a microcontroller that has been designed with capacitors and other components, see Figure 3.3 Figure System Tools, from the system produces the

magnitude of the power factor on an electrical network. When the value of the power factor is above 0.9, the microcontroller does not do the calculation, and if the power factor is below 0.9, the power factor must be corrected so that the microcontroller calculates the value of the capacitor that must be installed on the power network to combine the capacitors in the electricity network using a relay controlled by a microcontroller.



Figure 3.2: Capacitors

In determining the capacitor values for the system figure 3.2 capacitors must be seen in the market available capacitors, obtained in the market capacitor values, 1 microfarad, 2 microfarads, 4 microfarads, 8 microfarads, 16 microfarads and 25 microfarads, from which the six capacitors can be combined so that the value of 1 microfarad can be reached up to 56 microfarads.

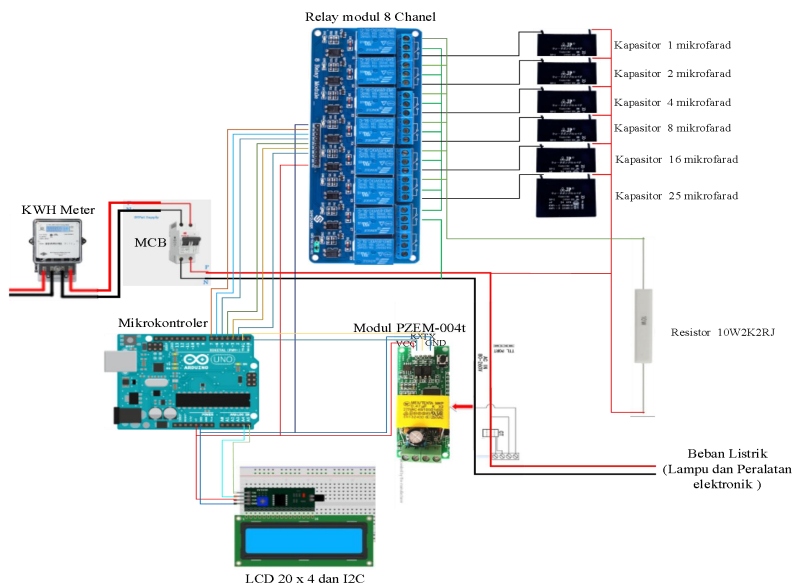

Figure 3.3: Tool System Drawings

### b. Power Factor Improvement

From subsequent experiments using the sensitivity analysis model, the simple method is the simulation model. The simulation was carried out at a customer power of 450 VA, with a 40 watt TL lamp electricity load, an 80 watt

refrigerator, a 50 watt fan, a 32 inch 40 watt Television. The load is installed on a system that has been made, where there is a capacitor in the system, the capacitor is controlled by the system, so it is connected to the load in parallel.

Observations were made on the results of the load measurement, where observations were made of the electrical load using the system, and at loads without using the system or without capacitors installed, the simulation was carried out by gradually adding loads. The following simulation results can be seen in Table 3.1 Simulation Results.

Table 3.1: Simulation Results

No	Volt	Curr.	Watts	VA	PF	Value Capacitors	information
<b>Simulation 1</b>							
1	226	0.35	44.00	74.25	0.58	-	Lamp 1 x TL 40 watts
2	226	0.24	44.30	51.52	0.84	2 mikrofarad	
<b>Simulation 2</b>							
3	224	0.71	86.00	152.30	0.54	-	Lamp 2 x TL 40 watts
4	225	0.46	87.60	94.00	0.85	5 mikrofarad	
<b>Simulation 3</b>							
5	223	1.06	120.90	231.60	0.53	-	Lamp 3 x TL 40 watts
6	223	0.66	120.30	142.00	0.84	8 mikrofarad	
<b>Simulation 4</b>							
7	223	1.44	163.00	317.00	0.52	-	Lamp 4 x TL 40 watts
8	221	0.86	163.00	190.00	0.85	11 mikrofarad	
<b>Simulation 5</b>							
9	220	2.09	249.00	454.00	0.55	-	Lamp 4 x TL 40 watts
10	221	1.34	245.00	286.00	0.87	15 mikrofarad	refrigerator 1 x 80 watt
<b>Simulation 6</b>							
11	220	2.18	296.00	477.00	0.62	-	Lamp 4 x TL 40 watts
12	219	1.56	292.00		0.85	11 mikrofarad	fan 1 x 50 watts

				345.00			refrigerator 1 x 80 watts
<b>Simulation 7</b>							
13	223	2.33	331	520.5	0.63	0	Lamp 4 x TL 40 watt
14	224	1.75	331	392	0.84	13 mikrofarad	fan 1 x 50 watts refrigerator 1 x 80 watts Television 32" x 40 watts
<b>Simulation 8</b>							
15	224	2.73	373.7	611.52	0.61	0	Lamp 5 x TL 40 watt
16	223	2.01	372	449	0.83	15 mikrofarad	fan 1 x 50 watts refrigerator 1 x 80 watts Television 32" x 40 watts

From the final simulation results it can be concluded that when the system is not installed, the electric power supply will be stopped when the current reaches 2 amperes, with an electric power of 249 watts. And for systems with capacitors installed, the installed power can exceed those not using the system, because the current used is still below 2 amperes, and the power using the system with capacitors after reaching 2 amperes the power used is 372 watts.

And furthermore if we do not use the system, then if we have to meet the power requirements, then what needs to be added is the PLN subscription power from 450 VA to 900 VA, so that it will incur more costs for power added costs and costs per kwh, because the tariff per kwh for 900 VA more expensive, the following calculation is based on the basic tariff of PLN, based on the final results of the simulation.

1. Calculation of costs without capacitors

- Total power of 373 watts
- Current 2.73 Amperes

Because the current is 2.73 amperes, the basic electricity tariff is taken from the 900 VA power rate of Rp. 1,300.

$$373 \text{ watts: } 1000 = 0.373 \text{ KWH}$$

With an average usage of 7 hours

$$0.373 \text{ KWH} \times 7 \text{ hours} = 2,611 \text{ KWH}$$

$$2,611 \times 30 \text{ days} = 78.33 \text{ KWH}$$

$$78.33 \text{ KWH} \times \text{Rp. } 1,300 = \text{Rp. } 101,829$$

2. Calculation of costs with capacitors

- Total power of 372 watts
- 2.01 Amperes current

Because the current is 2.01 amperes, the basic electricity tariff is taken from the 450 VA power rate of Rp. 415, -.

$372 \text{ watts} : 1000 = 0.372 \text{ KWH}$

With an average usage of 7 hours

$0.372 \text{ KWH} \times 7 \text{ hours} = 2,604 \text{ KWH}$

$2,604 \times 30 \text{ days} = 78.12 \text{ KWH}$

$78.12 \text{ KWH} \times \text{Rp. } 415, - = \text{Rp. } 32,419,8$

The above calculation does not include monthly load costs, where the monthly load costs are of course different tariffs between 450 VA and 900 VA subscriptions, in addition to that the added power costs are also a burden that must be incurred.

#### IV. Conclusion

1. The system can monitor the voltage, power consumption and current used at that time, so we know that the electric power used is optimal or not..
2. With this system can measure the electrical power used at the time, and improve the power factor if the power factor is low, the repair of the power factor is improved by capacitors installed in parallel on the network, the installation of the capacitors is controlled by a microcontroller, based on power and current requirements as measured by the PZEM-004t module.
3. Monitoring the use of electric power, voltage and current when we are not available through the internet, and can also control the electricity network remotely, so we do not need to worry when there is electronic equipment that forgets to turn off. And also can turn off and turn on the home page lighting even though we are traveling outside the city, so there is no need to keep the uterine lamp continuously while traveling.

#### REFERENCES

- [1] T. P. Abud ,P.P. Machado Jr ; M.Z.Fortes, B.S.M.C.Borba “Power factor metering system using Arduino”(2017), Niterói, Rio de Janeiro, Brazil.
- [2] Wasoontarajoen, Siriwat; Khwanchai Pawasan; Vithaya Chamnanphrai “ Development of an IOT for monitoring electrical Energy Consumption” (2017), Phuket, Thailand
- [3] Kabir Yasin, Yusuf Mohammad Mohsin, Mohammad Monirujjaman khan “Automated Power Factor Correction and Energi Monitoring System” (2017), Department of Electrical and Computer Engineering, North South University Bashundhara R/A, Dhaka-1229, Bangladesh.
- [4] Khan Muhammad Bilal, Muhammad Owais “Automatic Power Factor Correction Unit”, (2016), Department of Electronic Engineering Faculty of Engineering Sciences & Technology, Hamdard Institute of Engineering & Technology, Hamdard University Karachi, Pakistan
- [5] Habibi, Fatoni Nur; Sabar Setiawidayat; Moh. Mukhsim., “Alat Monitoring Pemakaian Energi Listrik Berbasis Android Menggunakan Modul PZEM-004T “ (2017), Prosiding Seminar Nasional Teknologi Elektro Terapan 2017, Vol.01 No.01, ISSN: 2581-0049
- [6] Noor Syamsudin, Noor Saputra “Efisiensi Pemakaian daya listrik menggunakan Kapasitor Bank” (2014), Jurnal Poros teknik, Volume 6, No. 2, Desember 2014 : 55 - 102
- [7] Shi, X., Dini, A., Shao, Z., Jabarullah, N.H. & Liu, Z. (2019) Impacts of photovoltaic/ wind turbine/ microgrid turbine and energy storage system for binding model in power system, Journal of Cleaner Production, 226, 845-857.



- [8] Almanda Deni. Ir, “Peranan Kapasitor dalam Penggunaan Energi Listrik” (2000), Nomor 30, Tahun VI, Elektro Online.
- [9] Harten,P Van; Ir. E. Setiawan ., “INSTALASI LISTRIK ARUS KUAT 2”(1992), Binacipta.
- [10] Santoso hari, “ Monster arduino 2” (2005), [www.ElangSakti.com](http://www.ElangSakti.com) .
- [11] Abdillah margiono, “ Merakit Kapasitor Bank Untuk Jaringan Listrik”, (2014), YKT Publisher.