

# IDENTIFICATION OF EUGENOL IN CLOVE OIL BASED ON ARRAY MOS GAS SENSOR USING PRINCIPLE COMPONENT ANALYSIS AND SUPPORT VECTOR MACHINE METHODS

<sup>1\*</sup>Agus Margiwiyatno,<sup>2</sup> Arief Sudarmaji

**ABSTRACT**--Recently the identification of Eugenol is mostly and accurately measured by means of MS-GC technique. However, it is difficult to be done by farmers or Small and Medium Enterprises (SMEs). One potential parameter of aromatic substance, particularly clove oil, to be measured is its vapor (gases and volatiles). This paper presents a non-destructive measurement of clove oil in various percentages based on Volatile Measurement System (VMS) using array of gas sensors. We build the VMS that consists of array of gas sensors in a sensor chamber, gas transport unit, acquisition unit, and data recognition units. We utilized 9 Metal Oxide Semiconductor (MOS) gas sensors run in dynamic mode using advanced Temperature Modulation (TM) method. We tested nine frequencies of Temperature Modulation to measure clove oil with three levels, i.e. 66.61%, 70%, and 88.24%. Principle Component Analysis (PCA) and Support Vector Machine (SVM) were used to obtain the best frequency which driven the MOS gas sensors in distinction the three clove oils. We found that the optimal frequency of TM was at frequency 4 Hz 75% with error validation accuracy is 13.56% using PCA and SVM technique.

**Keywords**—identification, eugenol clove array, principle ,component vecto machine methods

## I. INTRODUCTION

Essential oils are aromatic substances resulted from parts of plant. It is also called volatile oil and etheric oil since it is easily evaporate at room temperature (Gunawan and Mulyani, 2004). Clove oils, which produced from buds, leaves, roots, and stems, is one of export product and high price essential oils. The portion of Eugenol depends on the main part of plants. The leaf results about 74.3% of eugenol while from the bud, it results 49.7% of eugenol (Bhuiyan *et al.*, 2010). Currently the clove oil quality of products produced by farmers is around 70%. Clove oil with Eugenol levels of less than 70% is priced of Rp. 120,000.00 per kg (Widayat *et al.*, 2014). Most SMEs are difficult to know the quality of their products. Reliable and low cost instrument for indicating the clove oil quality for is really needed by the SME.

---

<sup>1</sup> Agricultural Engineering Study Program, Jenderal Soedirman University, Indonesia, agmargi@yahoo.co.id.

<sup>2</sup> Agricultural Engineering Study Program, Jenderal Soedirman University, Indonesia.

Recently Gas chromatography-Mass spectrometry (MS-GC) technique could accurately measure essential oil, like Eugenol. It is considered efficient and precise method for measuring all components. Identification of essential oil components is made using capillary GC with mass detector. Data resulted from the measurement can be used for determining oil purity by comparing to a reference profile of the oil (Dhole et al., 2012; Zellner et al., 2016). However, GC-MS has disadvantages as follows: high cost, time-consuming, and need large size (Lee and Lee, 2001).

One potential parameter of aromatic substance, particularly clove oil is its vapor (gases and volatiles) which can be measured using gas sensor. Recently the most used with versatile applications of gas sensor is Metal Oxide Semiconductor (MOS) (Aleixandre and Gerboles, 2012; Wilson and Baietto, 2009; Berna, 2010). Sudarmaji et al. (2017) has successfully used nine MOS gas sensors to detect two essential oils, i.e. patchouli oil and clove oil. This paper presents a non-destructive measurement of clove oil in various percentages based on Volatile Measurement System (VMS) using array of gas sensors to distinct percentage of Eugenol in clove oils. The VMS consists of array of MOS gas sensors, gas transport unit, acquisition unit, and data recognition units.

## II. METHODS

### 1.1. Sample of clove oils

We tested three level of clove oils. The samples originated from SMEs in Banyumas regency. Then, the eugenol level of clove oils were determined using GC-MS. We chose 3 levels of eugenol, i.e. 66.61%, 70%, dan 88.24% to represent the low, medium, and high level of Eugenol.

### 1.2. Diagram of system

Measurement of clove oils using static headspace and static measurement can be seen in Figure 1 (Sudarmaji et al. (2017)). SH (Sample Headspace) of essential oil was 15 ml glass with rubber cap. Vapor was manually delivered to sensor chamber using a 1 ml syringe. Dry air (filtered by silica gel) is constantly pumped to the chamber and it is used as reference.

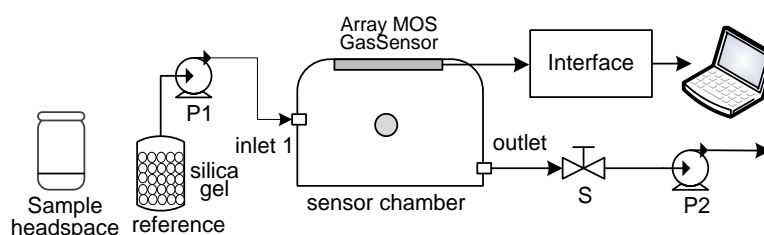

**Figure 1:** Static measurement for capturing essential oil vapor profile.

#### 1.2.1. Kind of MOS gas sensors

MOS Gas sensors can be seen in Table 1. Gas sensors were run in dynamic mode using TM-SDP (Temperature Modulation-Specified Detection Point) technique is shown in Figure 2. The sensors were placed in a chamber (11x9x7 mm) made from 5 mm transparent acrylic sheet. We also measure the temperature and oxygen level inside the sensor chamber using sensors of LM53 and KE-25 respectively.

The kinetic of MOS gas sensor was altered by temperature modulation due to changes in temperature of device during operation. Operating modulation voltage of the sensor changes periodically in rectangular waveform (Huang *et al.*, 2004).

In principle, the TM-SDP is similar to general temperature modulation whereas it modulates temperature of heater unit and sensing unit at the same phase with temperature modulation on the heater unit. Output of the sensor is set at a middle of sensing unit modulation (Sudarmaji and Kitagawa, 2015). Figure 1(c) shows the signal of TM-SDP.

**Table 1:** Gas and environment sensor for capturing essential oils profile.

No	Type	Main Target	Sensing Range
1.	TGS2602	Odorous gases (Ammonia, Ethanol)	1-100 ppm
2.	TGS 2620	Solvent (organic) vapors	50 – 5,000 ppm
3.	TGS 2600	Air Contaminants (H <sub>2</sub> , CO)	1-30 ppm
4.	MQ5	Natural gas, Coal gas	200-10,000 ppm
5.	MQ135	Air Quality Control	10-200 ppm
6.	MQ138	Wide volatile compound	200-10,000 ppm
7.	FIS12A	Methane	300-7,000 ppm
8.	FIS30SB	Alcohol	1-100 ppm
9.	FISAQ1	Volatile organic compound	10-10,000 ppm

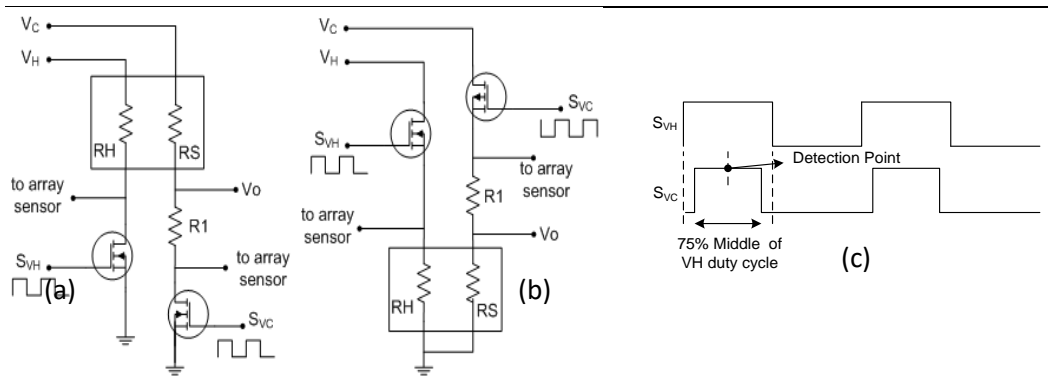

**Figure 2:** Sensor Circuit : (a) TGSs, MQs and (b) FISs (c) TM-SDP signal.

**1.2.2. Acquisition unit**

As center of interface unit, a PSoC CY8C28445-24PVXI was used for generating the TM-SDP signal for MOS gas sensors. The output of all sensors was collected by a computer by means of Radio Frequency using XBee serial communication (IEEE 802.15.4). A PSoC Designer 5.4 was employed to build program for the PSoC CY8C28445-24PVXI. Visual BasicNet 2012 was used to develop interface for data acquisition in Personal Computer.

### 1.3. Steps of Measurement.

There were 3 phases for measuring clove oils vapor: (1) reference capturing ( $R_O$ ), (2) vapor capturing ( $R_V$ ), and (3) purging. The  $R_O$  and purging phase were in the same value when there is no measurement of clove oil. The gas was forced to flow through a silica gel container by adjusting switch (S), pump-1 (P1), pump-2 (P2). The  $R_V$  was operated by injecting the vapor into sensor chamber and the switch (S), pump 1 (P1), pump 2 (P2) were turn off (see Figure 2).

In preparing sample, essential oil solution of 1 ml was injected onto the SH vial. Essential oils vapor (3 ml) in SH vial was also injected into sensor chamber. One cycle measurement of essential oil sample (**Figure 3**) involved acquiring  $R_O$  in a minute and then followed by acquiring  $R_V$  in a minute. Afterwards, the sensor chamber was purged in 10 minutes and then it backs to idle phase. 5 replications were made in every measurement.

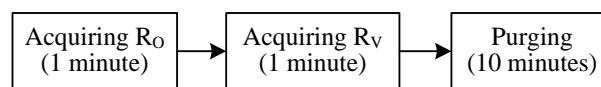

**Figure 3:** One cycle measurement.

Response of the sensors were presented by sensitivity ratio (equation 1).  $R_O$  is MOS resistance when measuring dry air and  $R_V$  is MOS resistance of the essential oil vapor. Higher sensitivity ratio value indicates higher ability of the sensor in detecting volatile compounds (Wang et al., 2010).

$$S = \frac{R_O}{R_V} \quad (1)$$

### 1.4. Analysis.

Three level of clove oil was treated in vapor measurement system with various modulation of TM-SDP. The treatments were (1) without modulation, (2) Frequency (F) modulation (F1=0.25 Hz, F2=1 Hz, and F3=4 Hz), and (3) Duty-cycle (D) modulation (D1=25%, D2=50%, and D3=75%). Thus there were ten TM-SDPs tested, namely no TM-SDP, 0.25hz;25%, 0.25hz;50%, 0.25hz;75%, 1hz;25%, 1hz;50%, 1hz;75%, 4hz;25%, 4hz;50%, and 4hz;75%.

Clove oil levels were classified by means of Principle Component Analysis (PCA) and Support vector methods (SVM) machine. The PCA was used as pre-processing tool and the SVM machine was used as classifying tool. These were to obtain the optimum TM-SDP as means to identify eugenol content in clove oil. We used Matrix Laboratory (MATLAB) software to analysis the response and classification.

## III. RESULT AND DISCUSSION

### 1.5. Measurement system of Clove oil.

Measurement system is presented in Figure 4. Table 2 shows configuration of PSoC CY8C28445-24PVXI. The wireless serial communication XBee (IEEE 802.15.4) was set to a direct transmission (point to point) using XCTU software. (Digi, 2008). The XBees was configured at 19200 bps, 8 bit of data, no parity, 1 stop bit and none flow control. The PSoC has analog and digital blocks (such as amplifier, filter, comparator, ADC, Timer, Serial Communication) which can be set/programmed as desired (Cypress, 2010).

A software developed by Visual Basic.Net 2012 was used to process. Signal and output of sensors can be seen in Figure. 4(b). Data storing and processing was done by using Microsoft Excel.

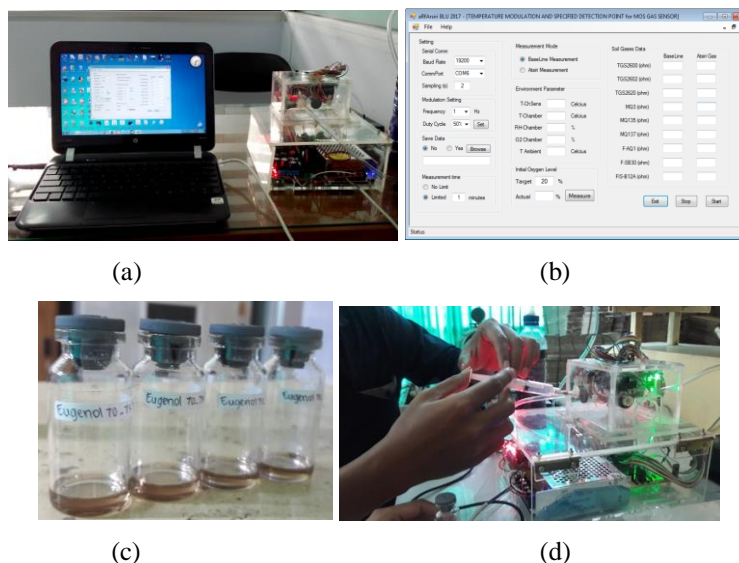

**Figure 4:** (a) Hardware of vapor measurement, (b) acquisition program interface, (c) SH vial of clove oils, and (d) vapor injection process.

**Table 2:** PSoC CY8C28445-24PVXI configuration for interface unit

Part	Important Configured Features
Global Resource	Sysclock=5V;24MHz, $V_{c1}$ = 2MHz, $V_{c2}$ =153,846kHz, $V_{c3}$ = 10kHz, Ref Mux= $\pm V_{dd}/2$ , Analog SC On/Ref High.
ADC	Clock= $V_{c1}$ , 14 bits, Unsigned data format, normal clock phase.
Incremental	
Dual ADC	Clock= $V_{c1}$ , 13 bits, Unsigned data format, normal clock phase.
Timer8	Clock= $V_{c3}$ , Capture=High, Terminal count and compare out= none, Period=9, Interrupt type=Terminal count Invert capture=normal.
PGA	2 PGAs connected to Dual ADC and 1 PGA to ADC Inc, Ref= $V_{ss}$
UART	Clock= $V_{c2}$ → 19200 kbps, 8 bit, no parity, 1 stop bit and none flow control
GPIO	- 14 pins connected to Analog Mux Input, drive as High Z analog. - 4 pins as Digital Output (StdCPU), drive Strong.

### 1.6. Individual response on MOS gas sensor.

Investigation was made to each MOS gas sensor response at various Temperature Modulation-SDP. For each Clove oil level, the measurements were acquired 30 data and repeated 5 times. Thus, we got 150 data/sample of Clove oil. For individual response of MOS gas sensor we used box plot analysis to show the ability of MOS to



We found strong indication that the the most sensitive and selective to sense the clove oils was TGS2602, followed by MQ138, MQ5, and TGS2620, MQ5. In contrary, FIS12A was found less sensitive in discriminating clove oil. the FIS12A were especially used to sense the methane, even though it could also be used to sense other gases. The Average of MOS gas sensors on all Temperature Modulation to sense the three Eugenol is shown in Figure 6.

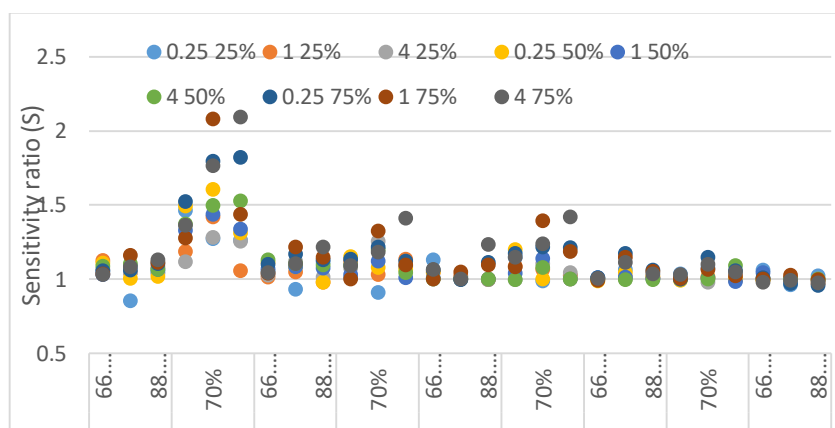

**Figure 6:** Average response of MOS gas sensors on all Temperature Modulation.

Presence of 21% ambient oxygen was minimal requirement for the gas sensors (such as TGSs) to work properly (Figaro Engineering Inc., 2005). Steady-state resistance behavior of the MOS gas sensor is greatly influenced by concentration of ambient oxygen. Reduced oxygen pressure will lead to decrement of the sensor resistance (Figaro Engineering Inc., 2005; Clifford and Tuma, 1982).

### 1.7. Classification of Eugenol using SVM and PCA+SVM

We applied SVM method as classification tool. And we compared between SVM and PCA+SVM methods. PCA acts as pre-processing tools. The PCA and SVM were analyzed using Matlab Software. Table 3 and Figure 7 shows the performance of identification of Eugenol that indicated by cross validation error. We found that the most optimum identification is by Temperature Modulation 4hz 75%. The cross-validation classification error was 13.56%.

It can be seen in Table 3 that the PCA improves the SVM classification in distinguishing Eugenol levels in Clove oil. The PCA can be used to reduce a large dimension of projection into a few important Principal Components (PCs) for projecting a dataset (using eigenvectors and eigenvalues) in a new coordinate system. Afterwards, covariance matrix of the dataset was calculate to reduce redundancy and maximizing variance (Hines *et al.*, 2003; Patel, 2014). The uncorrelated PCs showed significant variation (over 90%) in all variables (Hines *et al.*, 2003).

**Table 3:** Comparison of Classification Error between SWM and PCA+SVM to discriminate Eugenol of Clove oils.

Identificaton Method	Temperature Modulation	PCA PC 1	PCA PC 2	Cross Validation Classification Error
----------------------	------------------------	----------	----------	---------------------------------------

SVM	No Modulation	-	-	63.18%
SVM	0,25 Hz 25%	-	-	61.69%
SVM	1 Hz 25%	-	-	57.21%
SVM	4 Hz 25%	-	-	58.21%
SVM	0,25 Hz 50%	-	-	56.72%
SVM	1 Hz 50%	-	-	66.83%
SVM	4 Hz 50%	-	-	58.21%
SVM	0,25 Hz 75%	-	-	49.75%
SVM	1 Hz 75%	-	-	53.73%
SVM	4 Hz 75%	-	-	48.26%
PCA+SVM	NO	40,12%	24,89%	50.67%
PCA+SVM	0,25 Hz 25%	65,73%	14,09%	46.89%
PCA+SVM	1 Hz 25%	28,27%	17,50%	44.67%
PCA+SVM	4 Hz 25%	28,61%	14,79%	31.33%
PCA+SVM	0,25 Hz 50%	39,16%	18,09%	31.33%
PCA+SVM	1 Hz 50%	26,28%	17,35%	20.44%
PCA+SVM	4 Hz 50%	27,91%	16,20%	25.22%
PCA+SVM	0,25 Hz 75%	52,76%	17,75%	24.22%
PCA+SVM	1 Hz 75%	38,03%	23,96%	27.56%
PCA+SVM	4 Hz 75%	51,06%	17,10%	<b>13.56%</b>

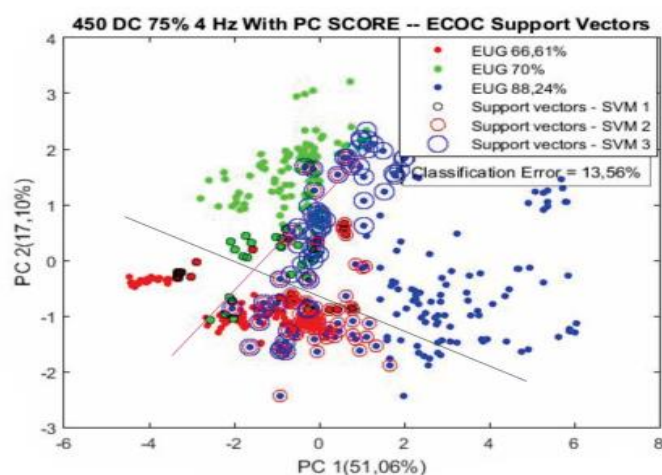

**Figure 7:** Identification performance of PCA+SVM method in discriminating 3 Eugenol levels by Temperature Modulation 4Hz 75% of MOS gas sensor.

#### IV. CONCLUSION

MOS gas sensors showed good performance for measuring of clove oils. For this purpose, the dynamic mode using TM-SDP technique was successfully used to measure 3 Eugenol levels of Clove oil. It was strongly indicated that the TGS2602, MQ5, MQ138, and TGS2620 has good sensitivity to determine Clove Oil. By using PCA+SVM tools, The most optimum identification was produced by using Temperature Modulation 4hz 75%.



The cross-validation classification error was 13.56% by operating the MOS gas sensors at Temperature Modulation 4 Hz 75% in dynamic mode.

## V. ACKNOWLEDGEMENTS

Great thank is addressed to Jenderal Soedirman University and DIKTI for providing fund through Riset Unggulan 2018 scheme for this research.

## REFERENCES

1. Aleixandre, M., and Gerboles, M. (2012). Review of small commercial sensors for indicative monitoring of ambient gas. *Chemical Engineering Transactions*, 30(SEPTEMBER 2012), 169–174. <https://doi.org/10.3303/CET1230029>
2. Bermak, A., Belhouari, S. B., Shi, M., and Martinez, D. (2005). Pattern Recognition Techniques for Odor Discrimination in Gas Sensor Array. *The Encyclopedia of Sensors*, X, 1–17.
3. Berna, A. (2010). Metal Oxide Sensors for Electronic Noses and Their Application to Food Analysis. *Sensors*, 10(4), 3882–3910. <https://doi.org/10.3390/s100403882>
4. Bhuiyan, N. I., Begum, J., Nandi, N. C., and Akter, F. (2010). Constituents of the essential oil from leaves and buds of clove (*Syzygium caryophyllatum* (L.) Alston). *African Journal of Plant Science*, 4(November), 451–454.
5. Carlo, S. Di, and Falasconi, M. (2012). Drift Correction Methods for Gas Chemical Sensors in Artificial Olfaction Systems: Techniques and Challenges. *Advances in Chemical Sensors*, 305–326. <https://doi.org/10.5772/33411>
6. Clifford, P. K., and Tuma, D. T. (1982). Characteristics of semiconductor gas sensors I. Steady state gas response. *Sensors and Actuators*, 3, 233–254. [https://doi.org/10.1016/0250-6874\(82\)80026-7](https://doi.org/10.1016/0250-6874(82)80026-7)
7. Cypress. (2010). *Programmable System-on-Chip (PSoC): CY8C28243/ CY8C28403/ CY8C28413/ CY8C28433/ CY8C28445/ CY8C28452/ CY8C28513/ CY8C28533/ CY8C28545/ CY8C28623/ CY8C28643/ CY8C28645* (001-48111 Rev. \*H). San Jose, CA. Retrieved from <http://www.cypress.com/?docID=50827>
8. Dhole, V. R., Sitharaman, B., and Kaur, I. (2012). *Characterization and Identification of Essential Oil Components by GC-MS*. Maharashtra, India.
9. Digi. (2008). *X-CTU Configuration and Test Utility Software: User's Guide*.
10. Figaro Engineering Inc. (2005). *General Information For TGS Sensors: Technical Information on Usage of TGS Sensors for Toxic and Explosive Gas Leak Detectors*. Retrieved from [http://www.figarosensor.com/products/common\(1104\).pdf](http://www.figarosensor.com/products/common(1104).pdf)
11. Gunawan, D., and Mulyani, S. (2004). *Ilmu Obat Alam (Farmakognosi)* (Jilid 1). Jakarta, Indonesia: Penebar Swadaya.
12. Hierlemann, A., and Gutierrez-Osuna, R. (2008). Higher-order chemical sensing. *Chemical Reviews*, 108(2), 563–613. <https://doi.org/10.1021/cr068116m>
13. Hines, E. L., Boilot, P., Gardner, J. W., and Gongora, M. A. (2003). Pattern Analysis for Electronic Noses. In T. C. Pearce, S. S. Schiffman, H. T. Nagle, & J. W. Gardner (Eds.), *Handbook of Machine Olfaction* (pp. 133–160). Weinheim: WILEY-VCH Verlag GmbH & Co. KGaA.

14. Huang, X., Meng, F., Pi, Z., Xu, W., and Liu, J. (2004). Gas sensing behavior of a single tin dioxide sensor under dynamic temperature modulation. *Sensors and Actuators, B: Chemical*, 99(2–3), 444–450. <https://doi.org/10.1016/j.snb.2003.12.013>
15. Lee, D., and Lee, D. (2001). Environmental Gas Sensors. *IEEE Sensors Journal*, 1(3), 214–224.
16. Patel, H. K. (2014). *The Electronic Nose: Artificial Olfaction Technology*. (E. Greenbaum, Ed.). New Delhi: Springer. <https://doi.org/10.1007/978-81-322-1548-6>
17. Sudarmaji, A., and Kitagawa, A. (2015). Sensors & Transducers Temperature Modulation with Specified Detection Point on Metal Oxide Semiconductor Gas Sensors for E-Nose Application. *Sensors & Transducers*, 186(3), 93–103.
18. Sudarmaji, A., Margiwiyatno, A., Ediati, R., and Mustofa, A. (2017). Vapor Measurement System of Essential Oil Based on MOS Gas Sensors Driven with Advanced Temperature Modulation Technique. In *AESAP 2017 Proceeding*. Bogor, Indonesia.
19. Wang, C., Yin, L., Zhang, L., Xiang, D., and Gao, R. (2010). Metal Oxide Gas Sensors: Sensitivity and Influencing Factors. *Key Laboratory for Liquid-Solid Structural Evolution and Processing of Materials*, 10, 2088–2106.
20. Wang, Chengxiang, Yin, L., Zhang, L., Xiang, D., and Gao, R. (2010). Metal Oxide Gas Sensors: Sensitivity and Influencing Factors. *Sensors*, 10(3), 2088–2106. <https://doi.org/10.3390/s100302088>
21. Widayat, Hilman, M., Bagus, B., and Rahmawan, A. (2014). Pengaruh Jenis Packing dan Tekanan Vakum dalam Peningkatan Mutu Minyak Cengkeh. In *Simposium Nasional RAPI XIII* (p. K-64-K-67). Surakarta, Jawa Tengah.
22. Wilson, A. and Baietto, M. (2009). Applications and advances in electronic-nose technologies. *Sensors*, 9(7), 5099–5148. <https://doi.org/10.3390/s90705099>
23. Zellner, B. d'Acampora, Dugo, P., Dugo, G., and Mondello, L. (2016). Analysis of Essential Oils. In K. H. C. Bas,er & G. Buchbauer (Eds.), *Handbook of Essential Oils: Science, Technology, and Applications: Second Edition* (2nd ed., p. 195–228). Boca Raton, FL: CRC Press Taylor & Francis Group.