

INTERACTIVE EFFECT OF WORK PLACE SPIRITUALITY AND JOB AUTONOMY WITH ORGANIZATIONAL BASED SELF -ESTEEM ON ORGANIZATIONAL LEARNING CULTURE

^{1*}Mansoor Hussain,²Amir Gulzar

ABSTRACT--*Learning has assumed added significance over the period of time and considered as key factor to the success of organizations. There is an ongoing debate among academics and practitioners alike about real essence of learning and its determinants. In this study the main purpose is to examine the role of organizational based self-esteem as one enabler of organizational learning culture. A model has been proposed to scientifically analyze the moderating effects of work place spirituality and job autonomy between organizational based self-esteem and organizational learning culture. Employees from private security companies participated in this research and linear regression analyses along PROCESS MACRO executed in SPSS are used to test hypotheses. This research positions work place spirituality and job autonomy in learning culture debate and implies that learning can be enriched by attending to spiritual enrichment and autonomous jobs. The research suggests a significant relationship between organizational based self – esteem and organizational learning culture, whereas moderation by work place spirituality is not proven.*

Keywords--*Organizational based self esteem, organizational learning culture, work place spirituality, job autonomy*

I. INTRODUCTION

Personal and Organizational values are considered highly relevant in organizational settings and any inconsistency among these values may lead to results which are detrimental to larger interest of both employees and organization. Incongruence in values also poses a sizable threat to self –esteem of employees which merits attention due to its strong explanatory power including associated learning and other positive outcomes **Invalid source specified..** Self - Esteem has emerged as an area of interest for researchers while focusing on the organizational, community, interpersonal, and individual effects **Invalid source specified..**

It may not be possible to ensure optimal performance while undermining actual abilities, competence and importance of individuals in organizational settings. When an individual is accorded value that is true to his or her beliefs; a feeling of *I count around here* is ingrained, which is one essential tenet of organizational based self

^{1*}Department of Business Administration, Foundation University Rawalpindi, Pakistan.,mansoor618@yahoo.com

²Department of Business Administration, Foundation University Rawalpindi, Pakistan..

esteem (OBSE). Such employees who associate high degree of value and meaningfulness with themselves exhibit engaging behaviors for organizations **Invalid source specified.**

In present day organizations stress has become a common phenomenon, whereas employees high in organizational based self esteem show composure against external stressors and negative information. Hence, positive organizational outcomes including intrinsic motivation, commitment and learning behaviors are determined by OBSE **Invalid source specified.** Capacity to produce these worthwhile outcomes by OBSE has brought this topic under sharp focus of researchers. Learning behavior is prime determinant of organizational learning culture (OLC) which is supportive for continuous learning for all members of the organization who are the ultimate architects of competitive advantage. Ongoing competitive environments warrant novel techniques to achieve competitive advantage **Invalid source specified.** **Invalid source specified.** stated that numerous practices, activities and values are instrumental towards creation of learning culture. In this regard organizational based self-esteem is also found to be related with high level of performance **Invalid source specified.** Organizational learning culture can prevail across the organization through individuals who are high in OBSE. These employees are likely to be high in motivation, productive and will display satisfaction. Through OBSE firsthand descriptions of behavior can be acquired instead of causes leading to behavior, therefore it extends novel insights into human behavior **Invalid source specified.** Numerous theories in the extant literature lend credence to these effects of OBSE which include self enhancement motivation theory **Invalid source specified.**, Cognitive consistency theory **Invalid source specified.** and self-protection theory (Korman, 2001). All these theories suggest that individuals with high OBSE tend to engage in behaviors through which positive self-image is reinforced.

Culture deemed supportive of learning by employees leads to consistency among values held strong by employees and goals of organization. On the other hand, those environments which run contrary to the actual spirit of learning lead to undermining of employees values **Invalid source specified.**

In their recent study **Invalid source specified.** collected sample from school students concluded that those individuals who have high self - esteem along with intrinsic motivation are likely to respond positively to learning strategies, whereas the direct link was found to be insignificant. These findings lead to the conclusion that OBSE alone cannot substantiate a linkage with learning culture, which creates a void warranting further exploration of the phenomenon. Although in the past, efforts have been made to understand the phenomenon but studies treating OBSE as one key factor that may influence essential work related outcomes could not be traced, hence being addressed in this study.

Present study aims at exploring the link between OBSE and OLC while collecting sample from private security guards. Private security industry is playing a critical role towards improving overall law and order situation in Pakistan. It has range of functions that include protection to employees, infrastructure and personal security. Despite immense contribution to society, it is not been able to attract the attention of researchers. Hence, numerous problems faced by employees associated with this industry remain unresolved **Invalid source specified.** Most of these companies do not follow the labour law which deprives the employees from their rights. Appropriate Human resource mechanisms including training and recruitment are almost non-existent. Hence, present practices of security companies are disproportionate to the magnitude of task they are assigned. To regulate the functions of these security companies a central body has been established called All Pakistan Security Agencies Association,

mainly to standardize the practices conforming to code of conduct but this organization is also without an powers to ensure compliance **Invalid source specified.**

Moreover, to crystallize the findings it also becomes imperative to understand the process through which this effect is taking place and circumstances under which the effect is operating **Invalid source specified.** purpose, the findings of Dreyer and Hermans (2014) were considered relevant and pertinent where it was stated that people must have full awareness about themselves along deep sense of purpose which becomes consistent with definition of workplace spirituality (WPS) which fulfils an individual's need for delight, meanings and esteem. Hence, it becomes pertinent to include WPS in this study as moderator, which is consistent with the findings of James, Miles, and Mullins (2011) who suggested to examine the impact of workplace spirituality on variety of variables to further crystallize the concept and enabling the managers to follow a business model that creates space for employees to work while adhering to their respective beliefs. In a study conducted by Maltby, Lewis, & Day (1999) it was argued that WPS is likely to assume an important role to predict OBSE, which leads to mitigate stress and also predicts satisfaction and wellbeing. According to James et al., (2011), spirituality has a central role in workplace which needs to be fully understood by employers. Fostering WPS in organizations by employers facilitates establishing highly functional environments for work, which promotes connectedness, sense of purpose and amicable relationships between employees, which further substantiates inclusion of this construct as moderator.

Additionally, providing some liberty in decision making to the employees results into alleviation of the impacts created by job demands and keep the employees engaged and motivated. Through the sense of involvement a perception of enhanced level of personal resources is created which is considered imperative towards coping with job demands **Invalid source specified.** It becomes consistent with the concept of job autonomy (JA) which is the freedom given to employees to take decisions in the job. Such employees make dedicated efforts to meet emerging challenges whereas, imposing excessive controls runs contrary to the interest of organization **Invalid source specified.** The relevance of JA and WPS established by these arguments merited exploration of their impact in this study on the relationship between OBSE and OLC. This research is also crafted with a goal of laying a foundation for future knowledge development in the domain of self- esteem while exploring its connections with other variables.

II. LITERATURE REVIEW

Creation of new ideas and knowledge is a skill that should be honed to perfection for survival of organizations. Even if new ideas or knowledge are not an immediate requirement of organization, the process merits recognition by institutionalization of system where knowledge repository is created while keeping it readily available for each member of organization to meet any future requirement. It is not in the realm of possibility to find immediate results from creation of new ideas, because new knowledge only gradually transforms an organization into a better outlook. Similarly, in the context of OLC useful knowledge is always retained and valued as precious commodity in one form or the other so that it may be of use at some point in time in future **Invalid source specified.** Banerjee, Gupta, and Bates (2016) also stated that in organizations where new ideas are not supported, cannot provide an environment for employees to share knowledge. Free flow of new ideas and knowledge sharing requires culture supportive of learning. OLC is considered as a concept which is close to learning environment or learning climate.

In work environment there are certain attributes which can easily be observed and measured which are termed as organizational climate **Invalid source specified.**, whereas culture is made up of values and beliefs of individuals regarding organization **Invalid source specified.** The concept of OLC has been derived from learning organization which is said to prevail when learning is considered as an important tool for success of business **Invalid source specified.**

Personal adequacy is a feeling that is likely to develop in those individuals of organization who are high in OBSE. It also strengthens the association of employees with organization. Moreover, it also becomes pertinent to mention that employees who are identified as valuable and meaningful for organization are likely to exhibit engaging behaviors, while extending support for others and creating supportive culture **Invalid source specified.** It is driving force for employees to discard behaviors which run contrary to the organizational interest **Invalid source specified.** OBSE leads to promotion of desirable behaviors in organizations in addition to inhibition of negative behaviors, primarily due to predominant feelings of being valued in organization.

While keeping in view these arguments it is assumed that employees with high degree of OBSE will act in way which is consistent with OLC. This leads to first hypothesis of the study as given:-

HI: Organizational based self-esteem has positive impact on organizational learning culture.

Present day organizations have redefined challenges for employees and employers alike, wherein work demands have assumed different outlooks. Now a day's people at an average spend more time at work while performing tasks that warrant added focus, dedication and commitment. Therefore, involvement of only body and mind towards work has become a trivial concept and need to involve soul and spirit as well has assumed added significance **Invalid source specified.**

Due to complexity of the construct it is not possible to define WPS in some widely accepted terms **Invalid source specified.** One preferred terminology used by researchers for WPS is meaningful workplace, while considering WPS as an important determinant of meaningful workplace **Invalid source specified.** Spirituality can be regarded as feeling of deep seated connection with others, self and universe which elevates personal awareness. Moreover, the domain of spirituality is different from religion, therefore it can be stated that that an individual may not be necessarily religious to practice spirituality. It is about an individual's logical needs for delight, adoration and meaning **Invalid source specified.** WPS is related to advantageous outcomes for organizations and with provision of opportunity for spiritual growth chances of better performance increase manifolds. It has also been found that given the high degree of self-awareness, employees tend to remain satisfied and happy despite all odds of job pressures **Invalid source specified.**

Spirituality is being discussed by employees in informal way and considered to be a part of their efforts to accomplish the tasks **Invalid source specified.** In the past efforts have been made to understand Work Place Spirituality, but taking it as key factor towards important outcomes related to work is a missing link. The challenge is to accommodate the spiritual needs without compromising the organizations operational brilliance **Invalid source specified.**

Spirituality has pivotal role towards promoting OBSE which leads to countering stress positively. Additionally, it also predicts well- being and satisfaction **Invalid source specified.** WPS surfaces from interactive effects of personal actions, personality traits and organizational features, paying attention to organizational cultures and contexts which act as spirituality fostering and friendly environments. Moreover, in environments which are

supportive of learning, spirituality of individuals is respected, nurtured and corresponds to values of organization. Simply stating WPS has association with OLC **Invalid source specified**. Hence, next hypothesis of study is

H2: Workplace spirituality has positive impact on organizational learning culture.

Those aspects of job that facilitate achieving meaningful goals related to work are called job resources. To handle effectively certain job demands these job resources have proven their effectiveness **Invalid source specified**. Job autonomy is one instance of job resource and reflects the liberty provided to employees in taking certain decisions and scheduling of work. With autonomy in job individuals willingly make endeavors to pursue tasks which otherwise deem beyond the scope of organization **Invalid source specified**. Job Autonomy is one case of job resource which shows the freedom towards performing certain tasks and decision making **Invalid source specified**.

While keeping these arguments in view it becomes pertinent to test following hypothesis,

H3: Job autonomy has positive impact on organizational learning culture.

Moreover, WPS is considered as a construct with strong explanatory power with positive influence on work related outcomes **Invalid source specified**. Spirituality is continuously evolving debate and has become central to organizational thinking process. Hence, time is ripe to bring spiritual realities under open discussion **Invalid source specified**. Seeing the necessity to grasp the process **Invalid source specified** through which OBSE is influencing OLC it may be assumed that WPS and JA will moderate the relationship between OBSE and OLC. Therefore, this discussion logically converges into next two hypotheses as following,

H4: Workplace spirituality moderates the relationship between organizational based self-esteem and organizational learning culture such that the high WPS will strengthen the relationship.

H5: Job autonomy moderates the relationship between organizational based self-esteem and organizational learning culture such that the high WPS will strengthen the relationship.

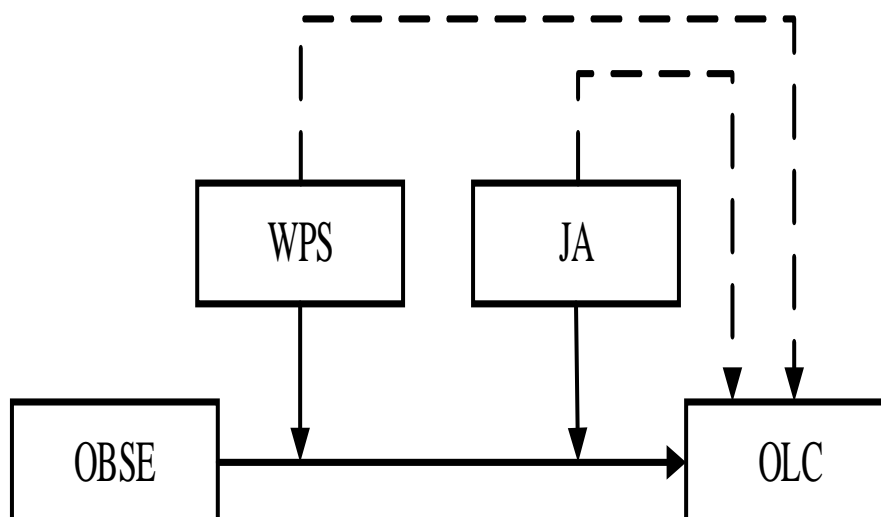

Figure1: Model of Organizational based Self Esteem and Organizational Learning Culture Relationships

Source: Researchers own processing

III. METHODOLOGY

Self-administered questionnaire was used for the purpose of collecting data for this study while employing convenience sampling method. It enabled the researcher to reach maximum numbers of respondents in limited time. Acquiring information on variables of interest from employees of private security companies was main goal of data collection process. All items were measured on five point likert scale ranging from strongly disagree to strongly agree except demographic ones.

Focus of this study was on corroboration of envisaged relationships; therefore hypotheses are tested while making use of regression analysis and PROCESS macro implemented in SPSS. Rigorous method of hypothesis testing has been used to enable the researcher to explain the nature of certain relationships among the variables of interest and predict variance in OBSE and OLC **Invalid source specified..** CFA is also used to ascertain consistency of model with data for essential theory testing. This consistency is determined with the help of fit statistics **Invalid source specified..**

Sample characteristics

Aggregate of 674 questionnaires could be retrieved from 1300 questionnaires which were distributed. Hence response rate was 51.84 % which is taken as acceptable because minimum standards to this effect are not established **Invalid source specified..** These participants were found occupying various positions in security companies. 10 % were from supervisory and managerial positions whereas 90% were security guards. Age of respondents ranged from 20 to above 60 years. Majority was found within the age bracket of 21-30 years. In sample total of 48% employees had experience 6-10 years whereas and this percentage decreased in each successive bracket. Hence, attrition rate was at increase beyond 6-10 years of working. This pattern is worth studying in some future research.

Only six respondents figured out as master degree holders whereas 60.7% had education up to Matriculation level only. Moreover, it was also found that male employees were in vast majority with only two found as females.

Instrumentation and Measures

An instrument with demonstrated reliability and validity across regions comprising of ten questions introduced by **Invalid source specified..** was considered appropriate to measure OBSE. To measure OLC a shorter version of Dimensions of Learning Organization Questionnaire (DLOQ) questionnaire was used which identifies OLC as construct with seven dimensions. Original questionnaire has total of 42 items which cannot be conveniently responded **Invalid source specified..** For WPS, instrument comprising of six items was used. Scale was suitably adapted to match the requirements of study. This instrument was developed after consultations with leading businessmen and religious scholars by **Invalid source specified..** Four items instrument was adopted from Korean employees job stress scale to measure job autonomy. It was developed by Korea occupational safety and health agency (2004). This scale is extensively used in extant research and has become increasingly popular among researchers over the period of time **Invalid source specified..**

Cronbach alpha statistics along with a sample item respecting all constructs are shown in Table1.

Table 1: Reliability statistics

Construct/Sample item	Items	Source	Cronbach alpha
OLC <i>My organization makes its lessons learnt available to all employees</i>	7	Invalid source specified.	0.95
JA <i>I am able to schedule when I work</i>	4	Korea Occupational Safety and Health Agency (2004)	0.72
OBSE <i>I count around here</i>	10	Invalid source specified.	0.73
WPS <i>I show patience with others</i>	6	Invalid source specified.	0.71

Coefficients of all variables have value more than 0.7 therefore considered reliable **Invalid source specified..**

Common method bias (CMB) is that variance which is likely to surface due to measurement method instead of questionnaire being used **Invalid source specified..** To offset any such influence Harman’s single factor test is used and factor variance remained 42.025 % which is acceptable. CMB has no influence on the data if variance is less than 50% **Invalid source specified..**

IV. RESULTS AND FINDINGS

Pearson correlations are calculated and given in table 2. All values are found significant ($p < .001$) and in the expected directions. For this study these correlation results do not lead to acceptance of hypotheses. Descriptive statistics are also shown in table 3, which reflects description of data while providing foundation for later analyses.

Table 2: Pearson Correlations

OLC	JA	OBSE	WPS
OLC	-		
JA	.507**	-	
OBSE	.526**	.811**	-
WPS	.317**	.531**	.481**

Note: ** Correlation found significant at $p < 0.001$ level (2_tailed)

Table 3: Descriptive Statistics

Constructs	Range	Minimum	Maximum	Sum	Mean	Std. Deviation
OLC	4.00	1.00	5.00	2502.29	3.7181	.10834
JA	3.75	1.25	5.00	2722.00	4.0446	.70675
OBSE	3.90	1.10	5.00	2778.40	4.1284	.67701
WPS	3.17	1.83	5.00	2717.67	4.0441	.57960

To determine essentially required consistency of model with data, Confirmatory Factor Analysis (CFA) was conducted while making use of various fit indices which indicated acceptable fit. Value of $\chi^2/df = 2.766 (< 3)$, RMSEA = .051 ($\leq .08$) and SRMR = .038 ($\leq .05$). Moreover, values of TLI, CFI and IFI are .903, .911 and .911 respectively while meeting the cutoff level ($\geq .90$). Similarly, all factors loadings ranged from 0.56 to 0.9, hence considered acceptable.

Regression analysis was carried out to test the direct hypothesis. It was found that OBSE has positive and significant impact on OLC ($\beta = 0.526, p < .000$). These results are reflected in table 5. This finding lends credence to H1 of this study, hence stands accepted. Workplace Spirituality and job autonomy were also found to have positive and significant impact on OLC with results as ($\beta = 0.317, p < .000$) and ($\beta = 0.507, p < .000$) respectively (Table 6 and 7). Therefore, H 2 and H 3 were accepted.

Last two hypotheses pertaining moderating effect were tested through model 1 in PROCESS MACROS 3 developed by Hayes (2017) in SPSS. According to next hypothesis WPS moderates the relationship between OBSE and OLC. Results were calculated at 95% confidence interval with 5000 bootstrapped samples in PROCESS MACROS 3 model 1. No signs of moderation figured out with insignificant interaction ($p > .05$) and zero between both limits of confidence interval (LLCI = -.06, ULCI = 0.32). Hence H 4 of the study was rejected. On the other hand, job autonomy had significant moderating effect between OBSE and OLC ($p < .05$) and zero value also did not lie between limits of confidence interval (LLCI = 0 .0031, ULCI = 0.2453). Conditional moderation of job autonomy at values ranging from small to high was also significant. At the lower most value (effect = .7011, $p < .05$) and point estimates also indicate that zero is not there between lower and upper limits of confidence interval (LLCI = .4712, ULCI = .9310). At intermediate level effect was again significant (effect = .7632, $p < .05$) without zero between the bounds of confidence interval (LLCI = .4908, ULCI = 1.0356). Similarly, at the uppermost value of Job Autonomy again significant impact was established (effect = .7942, $p < .05$) and further reinforced by non - existence of zero among lower and upper bounds (LLCI = .4983, ULCI = 1.0902) of confidence interval. These results lead to the acceptance of H 5 of the study. Moderation results are stipulated in table 8 and 9.

Table 4: Regression Analysis - OBSE and OLC

	Unstandardized Coefficients		Standardized Coefficients			
	B	Std. Error	Beta	t	F	Sig.
(Constant)	.162	.225				
OBSE	.861	.054	.526	16.029		.000
					257	.000

Dependent Variable: OLC

Table 5: Regression Analysis – WPS and OLC

	Unstandardized Coefficients		Standardized Coefficients			
	B	Std. Error	Beta	t	F	Sig.
(Constant)	1.268	.286				
WPS	.606	.070	.317	8.640		.000
					75	.000

Dependent Variable: OLC

Table 6: Regression Analysis – JA and OLC

	Unstandardized Coefficients		Standardized Coefficients			
	B	Std. Error	Beta	t	F	Sig.
(Constant)	.505	.214				
JA	.794	.052	.507	15.22		.000
					231.663	.000

Dependent Variable: OLC

Table 7: Results for Moderation

Interaction	Coefficient	SE	t	P	LLCI	ULCI
OBSE x WPS	.13	.09	1.38	.17	.06	.32
OBSE x JA	.1242	.0617	2.0131	.0445	.0031	.2453

Dependent; OLC

Table 8: Conditional Effects at Various Values of Moderator – JA

Values of JA	Effect	SE	t	p	LLCI	ULCI
Low	.7011	.1171	5.9869	.0000	.4712	.9310
Medium	.7632	.1387	5.5017	.0000	.4908	1.0356
High	.7942	.1507	5.2691	.0000	.4983	1.0902

V. DISCUSSION

This study explored the importance of organizational based self-esteem towards shaping the environmental context for learning and at the same time stimulating perception of employees that their lives and work have meaning. This enables the employees to harmonize efforts for integrating their energy and lives for work. This is in line with the findings of **Invalid source specified.** The strong and positive impact of organizational based self-esteem on organizational learning culture as found in this study ($\beta = 0.526, p < .000$) indicates that individuals who are accorded value in organization and consider themselves meaningful, engage in behaviors which are in larger interest of organization and become an important determinant of learning culture. This lends credence to H1 of this study. According to the results Workplace Spirituality has significant and positive impact on OLC ($\beta = .317, p < .000$), although the coefficient of regression is not very strong yet emerging significant while signaling a connection with organizational learning culture without any contradiction with extant literature. According to Howard (2002), spirituality has strong connections with learning capabilities and emotions, rather these are interwoven concepts. It is imperative for all humans to embrace spirituality and learning as core components of their personality. Same is true for organizations also where by virtue of learning employees may infer and take decisions about their actions in various circumstances which warrant courage. It is through deep seated relationship with spirituality that essentially required strength is mustered. Sorakraikitikul and Siengthai (2014) also explored strong association between work place spirituality with organizational learning culture. These arguments are consistent with H2 of this study.

Similarly, with organizational learning culture; Job Autonomy exhibited a positive and significant influence ($\beta = 0.507, p < .000$). Individuals entrusted with independent responsibilities with leverage to find solutions are more likely to engage in learning activities while contributing directly towards creation of learning culture which is consistent with previous research for example in a research undertaken by **Invalid source specified.** it was explored that employees with requisite autonomy given in their jobs are more inclined to knowledge sharing activities. Hence, acceptance of H3 of this study is in line with findings of previous studies on the subject.

Moderating effect of workplace spirituality between organizational based self-esteem and organizational learning culture was not significant while rejecting H4. Seeing the strong explanatory power of work place spirituality and proven linkage with organizational based self-esteem and organizational learning culture; significant moderating effect was expected. Since Private security companies formed the population of this study which is not analyzed against the construct of workplace spirituality in the past, hence this may be one reason for the rejection of hypothesis. In some future research deep down processes through which these effects come to operation and specific boundary conditions of these effects in question may be explored.

On the other hand H5, of study is supported because job autonomy has significant moderating effect between organizational based self-esteem and organizational learning culture. Moreover, conditional effects at different levels of job autonomy indicate that with job autonomy at maximum value the corresponding effect of organizational based self-esteem on organizational learning culture will increase which further crystallize the importance of autonomous jobs. Although, the moderating effect of job autonomy on the relation between organizational based self-esteem and organizational learning culture is not explored in the past but positive influences on these two constructs are evident, hence findings of this research shall not be considered to contradict the extant literature.

VI. IMPLICATIONS

Empirical research on work place spirituality is limited, therefore through this study; in management and organizational literature a void is filled. Findings of this research have important implications in both theory and practice. Leaders in organization and practitioners in human resources development should be able to identify the critical role of spirituality in work place and job autonomy in the formulation of management strategy. It becomes imperative for practitioners to foster learning culture and focus on autonomous jobs with high degree of confidence as theory proves its efficacy from academic point of view duly supplemented by empirical findings.

Organizational learning culture has assumed added significance in organizational context and this research signifies the central role of organizational based self-esteem and work place spirituality towards developing a learning culture. Although organizational based self-esteem impacts organizational learning culture positively, job autonomy has figured out as an important condition to institutionalize a learning culture.

VII. CONCLUSION

The emphasis of this study was to examine the impact of organizational based self-esteem on organizational learning culture and exploration of process by which the impact is taking place. All the specified objectives were achieved by testing five hypotheses. The results indicate that every employee serving in organization irrespective of position is important and feelings of being valued lead to shaping motivation, behaviors and work related attitudes. Similarly, this research shows that construct of workplace spirituality is assuming added significance for organizations. Many employees have desire to lead lives according to spiritual demands and business leaders who are aware of spiritual path are making consistent efforts to refine their spiritual personality while focusing on the influence they have on organization and society as well. Therefore, it merits attention of academics and practitioners alike. In this research workplace spirituality did not figure out as moderator in the relationship between OBSE and OLC and cause may be traced in the provocative nature of the subject. Moreover, people are anxious and edgy about its inclusion in the domain of business and there also lies a need to draw up boundaries in debates regarding spirituality to arrive at a rationale viewpoint. From the perspective of learning culture; workplace spirituality figures out as leading indicator of performance which so far has been overlooked in the literature. In this study a learning culture has been identified as new context for job autonomy and workplace spirituality while creating new meanings for life and work. This study specifies the critical role of organizational learning culture as a mechanism towards development of employee values.

VIII. LIMITATIONS AND FUTURE RESEARCH

To generalize findings of this research there is need to exercise caution because scales used in this study are developed in different cultures and all respondents of this study are from Pakistan. Therefore, results obtained might have been influenced due to sensitivity of culture despite adhering to protocols of translation and valid results of scales. It is suggested that future research may be undertaken on cross-cultural basis to find out whether differences in cultures result into variation in findings. Moreover, to rule out any concern pertaining common method bias multiple sources of data collection may be used instead of only self-report instrument. Although, this effect is non-existent in this study as correlations are not excessively high. To further crystallize the findings, it is recommended that future research may employ longitudinal approach instead of cross sectional design used in this study. Additionally, qualitative design preferably using case studies is likely to substantiate results of this study. It would also be advantageous to examine the impact of organizational based self-esteem on certain different variables including job involvement, satisfaction, trust and absorptive capacity.

REFERENCES

1. Anthony, J. V. (2009). Examining the relationship of spirituality and religiosity to individual productivity in the united states. The dissertation submitted to North Central University, Graduate faculty of the school of Business and management in partial fulfillment of the requirements for the degree of PhD . Prescott Valley, Arizona.
2. Arshadi, N., & Damiri, H. (2013). The relationship of job stress with turnover intention and job performance: Moderating role of OBSE. *Social and Behavioural Sciences Journal*, 84, 706-710.
3. Bagozzi, R. P., & Yi, Y. (1991). Multitrait-Multimethod matrices in Consumer research. *Journal of consumer research*, 17, 426-439.
4. Banerjee, P., Gupta, R., & Bates, R. (2016). Influence of organizational learning culture on knowledge workers motivation to transfer training: testing moderating effects of learning transfer climate. *Journal of Curr Psychol*.
5. Berson, Y., Da'as, R. A., & Waldman, D. A. (2015). How do leaders and their teams bring about organizational learning and outcomes? 68, 79-108.
6. Dipboye, R. L. (1977). A critical review of Kormans self - consistency theory of work motivation and occupational choice. *Organizational Behaviour and human Performance*, 18, 108-126.
7. Dreyer, J. S., & Hermans, C. A. (2014). Spiritual character traits and leadership in the school workplace: An exploration of the relationship between spirituality and school leadership in some private and religiously affiliated schools in South Africa. *Koers Bulletin for Christian Scholarship*, 79(2), 8. doi:10.4102/koers.v79i2.2136
8. Fourie, M. (2014). Spirituality in the work place: An introductory overview. In *Die Skriflig*, 1769, 8. doi:doi.org/ 10.4102/ ids.v48i1. 1769
9. Gardener, D. G., & Pierce, J. L. (2011). A question of false self-esteem. *Journal of Managerial Psychology*, 26(8), 682-699.

10. Gardner, D. G. (1998). A question of false self-esteem. *Group and Organizational Management Journal*, 23(1), 48-70.
11. Grant, D., Neil, O., & Stephens, L. (2004). Spirituality in the work place: new empirical directions in the study of the sacred. *Journal of sociology of the Religion*, 65, 265-283.
12. Hackman, J. R., & Oldham, G. R. (1976). Motivation through the design of work: test of theory. *Organizational Behaviour and Human Performance*, 16(2), 250-279.
13. Hair, J. E., Black, W. C., Babin, B. J., Anderson, R. E., & Tatham, R. L. (2006). *Multivariate data analysis*. Upper Saddle River, NJ: Pearson/ Prentice Hall, .
14. Hayes, A. F. (2018). Partial, conditional, and moderated mediation: Quantification, inference, and interpretation. *Communication Monographs*, 85(1), 4-40.
15. Hislop, D. (2010). *Knowledge management in organizations* (2nd ed.). Newyork: Oxford University Press. Inc.
16. Howard, S. (2002). A spiritual perspective on learning in the workplace. *Journal of Managerial Psychology*, 17(3), 230-242.
17. Hung, R. Y., Yang, B., Lien, B. Y., Mclean, G. N., & Kuo, Y. M. (2010). Dynamic capability: impact of process alignment and OLC on performance. *Journal of world business*, 45, 285-294.
18. James, M. S., Miles, A. K., & Mullins, T. (2011). The interactive effects spirituality and trait cynicism on citizenship and counterproductive work behaviours. *Journal of Management, Spiritualityand Religion*, 8(2), 165-182.
19. Johnson, T., & Owens, L. (2003). Survey response rate reporting in the professional literature. 58th Annual Meeting of American association for Public Opinion Research. Nashville, tennesse.
20. Kalita, K. (2015). A comparative study of spirituality and burnout among employees in different sectors. Retrieved from www.Researchgate.net: [www.Researchgate.net/ publication/308693073](http://www.Researchgate.net/publication/308693073)
21. Kim, Y. (2016). Music therapists job demands, job autonomy, social support, and their relationship with burnout and turnover intention. *The Arts in Psychotherapy*, 51, 17-53.
22. kokkinos, C. M., & Voulgaridou, I. (2018). Motivational beliefs as mediators in the association between perceived scholastic competence, self-esteem and learning strategies among Greek secondry school students. *Educational Psychology*. doi:10.1080/01443410.2018.1456651
23. Korea Occupational Safety and Health Agency. (2004). Retrieved from Job stress measurement scale for korean employees: [http:// safedu.org/pds1/ 9633](http://safedu.org/pds1/9633)
24. korman, A. K. (1970). Towards an hypothesis of work behaviour. *Journal of Applied Psychology*, 54, 31-41.
25. Korman, A. K. (1971). Organizational achievement, aggression and creativity: some suggestions towards integrated theory. *Organizational Behaviour and Human Performance*, 6, 593-613.
26. Korman, A. K. (2001). *Self-enhancement and self-protection: Toward a theory of work motivation*. Erlbaum: Mahwah.
27. Korman, A. K. (n.d.). Self enhancement and self - protection: Towards a theory of work motivation. In M. erez, U. kleinbeck, & H. Thierry (Eds.) .

28. Liopis, O., & Foss, N. J. (2015). Understanding the climate-knowledge sharing relation: The moderating rules of intrinsic motivation and job autonomy. *European Management Journal*. doi:doi.org/ 10.1016/j.emj.2015.11.009
29. Liu, C., Spector, P. E., Liu, Y., & Shi, L. (2011). The interaction of job autonomy and conflict with supervisor in China and United States: a qualitative and quantitative comparison. *International Journal of Stress Management*, 18(3), 222-245.
30. Lyles, M. A. (2016). Leveraging Organizational learning and alliances in complex and changing business environments. *Global Entrepreneurship Past Present and Future*, 5-17. doi:doi.org/10.1108/S1571-502720160000029002
31. Maltby, J., Lewis, C. A., & Day, L. (1999). Religious orientation and psychological well being: the role of the frequency of personal prayer; religious orientation and psychological well- being. *British Journal of health psychology*, 4, 363-378.
32. Marsick, V. J., & Watkins, K. E. (2003). Demonstrating the value of OLC: Dimensions of learning organizational culture. *Advances in Developing Human resources*, 5(2), 132-151.
33. Matsunaga, M. (2010). How to factor analyse your data right: Do's and Do'n'ts, and how to,s. *International Journal of Psychological Research*, 3(1), 97-110.
34. Morgeson, F. P., & Humphrey, S. E. (2006). the work design questionnaire(WDQ): Developing and validating a comprehensive measure for assessing job design and the nature of work. *Journal of Applied Psychology*, 91, 1321-1339.
35. Nahrgang, J. D., Morgeson, F. P., & Hofmann, D. A. (2011). Safety at work: ameta-analytic investigation of the link between job demands, job resources, burnout, engagement, and safety outcomes. *Journal of Applied Psychology*, 96(1), 71-94.
36. Nikolova, I., Russeveldt, J. V., Dewitte, H., & Dama, K. V. (2014). Learning climate scale: construction, reliability and initial validity evidence. 85, 258-265.
37. Nikolova, S. M., Van, J. R., DeWitte, H., & Van, K. D. (2014). Learning climate scale: construction, reliability and initial validity evidence. *Journal of vocational behaviour*, 85, 258-265.
38. Pierce, L. J., Gardner, D. G., & Dunham, R. B. (1993). Moderation by organization based sel-esteem of role condition-employee response relationships. *Academy of Management Journal*, 36, 271-288.
39. Pierce, L., Gardner, D. G., Cummings, L. L., & Dunham, R. B. (1989). Moderation by OBSE: construct definition, measurement, and validation. *Academy of management Journal* , 622-648.
40. Roni, S. M. (2016). What is meant by common method bias? How do we test and control it? Retrieved from <http://www.research gate.net/post>
41. Schmitz, S., Rebelo, T., Gracia, F. J., & Tomas, I. (2014). Learning culture and knowledge management process: To what extent are they effectively related? *Journal of Work and organizational Psychology*, 30, 113-121.
42. Schneider, B., Ehrhart, M. G., & Macey, W. H. (2013). Organizational climate and culture. *Annual review of Psychology*, 64, 361-388.
43. Schutte, P. J. (2016). Work place spirituality: A tool or a trend? *HTS teologiese Studies/Theological Studies*, 72(4), 3294. doi:doi. org/ 10.4102/ hts.v72i4.3294

44. Sehgal, I. (2014). Regulating Pakistan,s private security industry. Retrieved from [http:// viewsweek.com/ viewsweek-exclusive/regulating-Pakistans-security-industry](http://viewsweek.com/viewsweek-exclusive/regulating-Pakistans-security-industry)
45. Sekaran, U. (2003). Research methods for business, a skill building approach (4th ed.). John Wiley and Sons, Inc.
46. Sorakraikitikul, M., & Siengthai, S. (2014). OLC and workplace spirituality, is knowledge sharing behaviour a missing link? *The Journal of Learning Organization*, 21(3), 175-192.
47. Steenkamp, P. L., & Basson, J. S. (2013). A meaningful work place: Framework, space and context. *HTS Teologiese studies/ Theological Studies*, 1258.
48. Strom, K., Berzofsky, M., Shook-Sa, B., Barrick, K., Daye, C., Horstmann, N., & Kinsey, S. (2010). The Private security industry: A review of the definitions, available data sources, and paths moving forward, literature review and secondary data analysis . 3040 Crnwallis road Research Triangle Park, NC 27709: RTI International.
49. Tombaugh, J. R., Mayfield, C., & Durand, R. (2011). Spiritual expression at work: exploring the active voice of workplace spirituality. *international Journal of Organizational Analysis*, 19(2), 146-170.
50. Unal, Z. M., & Turgut, T. (2016). Organizational culture and organizational based self- esteem as predictors of spirit at work. *Khazar Journal of Humanities and Social Sciences*, 19(4), 71-96.
51. Whelpley, C. E., & Mcdaniel, M. A. (2016). Self-esteem and counterproductive work behaviours: A systematic review. *Journal of Managerial Psychology*, 31, 850-863.
52. Yang, B., Watkins, K. E., & Marsick, V. J. (2004). The construct of learning organization: Dimensions, measurement, and validation. *Human Resource Development Quarterly*, 15(1), 31-55.
53. Yang, C. C. (2015). The integrated model of core competence and core capability. *Total Quality Management and Business Excellence*, 26, 1-17.